

# DESIGN AND DEVELOPMENT OF AN AUTOMATED CONTINUOUS HARVESTING SYSTEM FOR MICROALGAE PHOTOBIOREACTORS

**GROUP 9: UFPR - FSU FIPSE TEAM**  
**PRESENTATION DATE: NOVEMBER 17, 2015**

**PRESENTERS:**

YURI LOPES

BEN BAZYLER

COURTNIE GARKO

**ADVISOR(S):**

JUAN C. ORDONEZ<sup>1</sup> & JOSE V. C. VARGAS<sup>2</sup>

**SPONSOR:**

JUAN C. ORDONEZ

# TEAM 9 – TEAM MEMBER NAMES AND ROLES

- Kaelyn Badura<sup>1,2</sup> - UFPR Team Lead
- Yuri Lopes<sup>1</sup> - FSU Team Lead
- Ben Bazylar<sup>1</sup> - Finance and Inventory Manager
- Courtnie Garko<sup>1</sup> - Scale and Process Engineer
- Benalle Lemos<sup>2</sup> - Hydraulics Specialist
- Tomas Solano<sup>1,2</sup> - Lead Mechanical Engineer



<sup>1</sup>Florida State University, Tallahassee, Florida, USA; <sup>2</sup>Federal University of Paraná, Centro - Curitiba, Paraná, Brazil

# PROJECT OVERVIEW

## Goal Statement:

*Design of an automated and continuous harvesting system for microalgae for increased biomass production.*



**Fig 1.** Industry scale microalgae photobioreactor at NPDEAS (UFPR), Curitiba, Brazil.

# BACKGROUND INFORMATION - MICROALGAE

- Research in potential biodiesels such as soybeans, animal fats, and vegetable oils have opened a large field of study and mass production into these alternative natural fuel sources.
- Microalgae
  - High growth rate
  - Minimal usage of land
  - Potential to recycle and clarify used water
- Biomass is a value added product
  - Food stock
  - A source for dyes
  - Medical applications

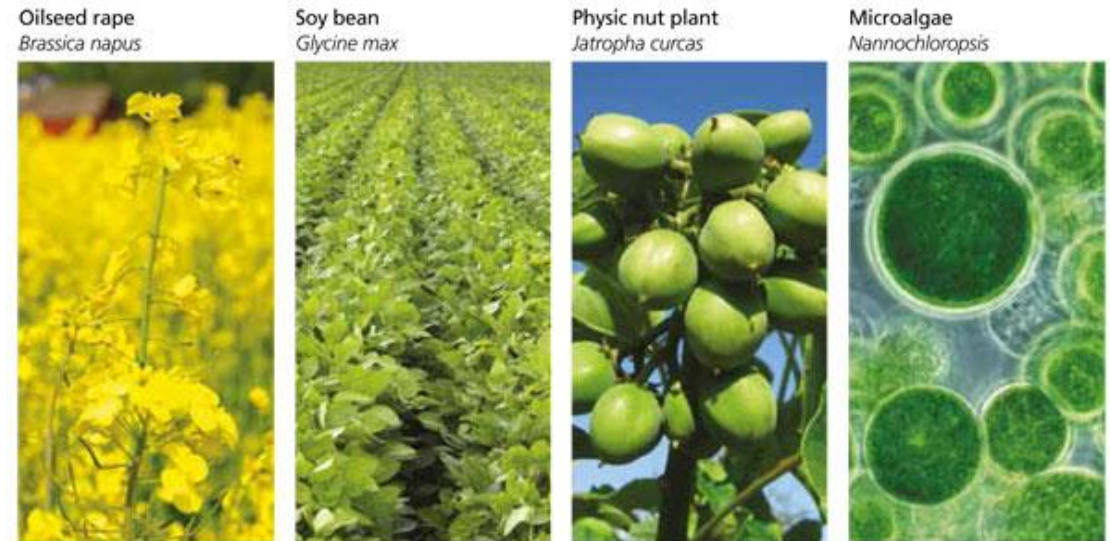

**Fig 2.** Image showing a select of various alternative crops for alternative production.

Crop	Oil yield (L/ha)	Land area needed (M ha) <sup>a</sup>	Percent of existing US cropping area <sup>a</sup>
Corn	172	1540	846
Soybean	446	594	326
Canola	1190	223	122
Jatropha	1892	140	77
Coconut	2689	99	54
Oil palm	5950	45	24
Microalgae <sup>b</sup>	136,900	2	1.1
Microalgae <sup>c</sup>	58,700	4.5	2.5

<sup>a</sup> For meeting 50% of all transport fuel needs of the United States.

<sup>b</sup> 70% oil (by wt) in biomass.

<sup>c</sup> 30% oil (by wt) in biomass.

## YIELD AND LAND USAGE OF OIL CROPS

Fig 3. table of various oil crops, their oil yield, land area required for yield, and its relative consumption of of existing cropping area (Christi, 2007).

# BACKGROUND INFORMATION - CULTIVATION

- Cultivation can be implemented as a closed or an open system.
  - Open - natural bodies of water or artificial ponds
    - Advantages: Ease and cost efficiency of installation and operation
    - Disadvantages: Larger land consumption, contamination, and difficulties with input control
  - Closed - Airlifts and photobioreactors
    - Advantages: Artificially or naturally illuminated, reliable condition control, space efficient
    - Disadvantages: Higher initial capital investment and requires more maintenance

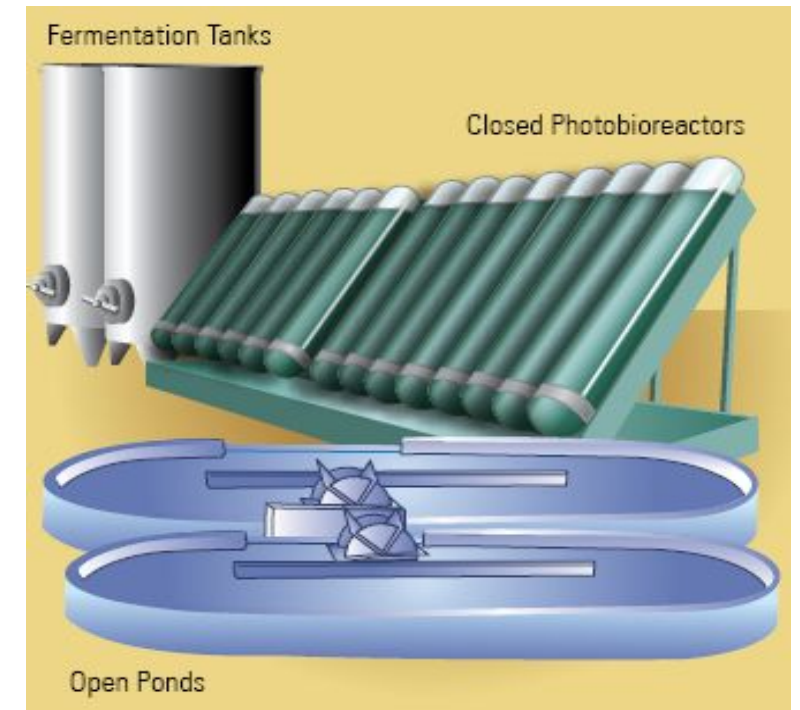
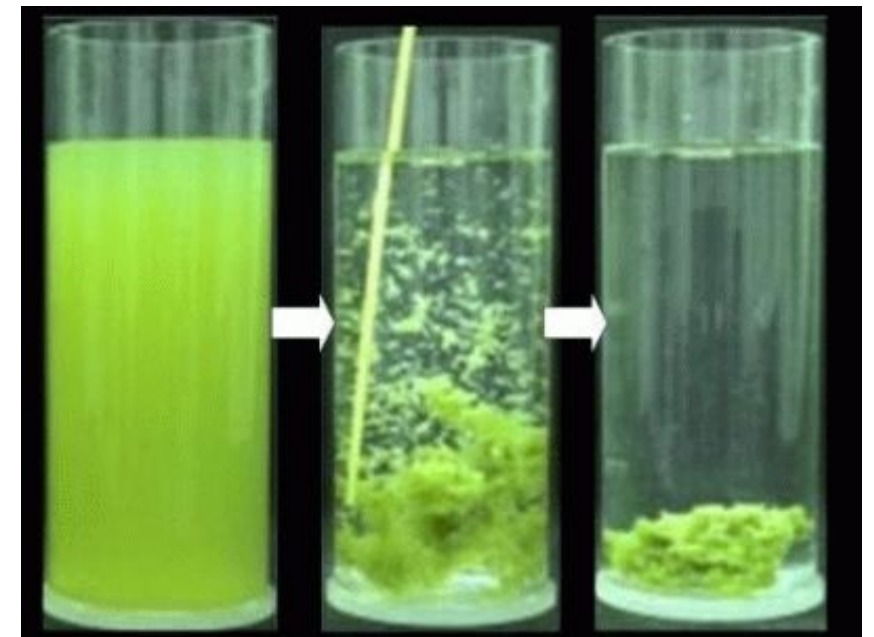

**Fig 4.** Two closed (PBR, fermentation tank) and one open (raceway pond) algae cultivation systems **6**



# BACKGROUND INFORMATION - HARVESTING

- Harvesting of microalgae is a process which involves flocculation, coagulation, clarification, and extraction.
- Flocculation is the process by which algae cells are modified so they will conglomerate.
- Types of flocculation:
  - Auto-flocculation
  - Chemical flocculation
  - Filtration
  - Centrifugation
  - Electric means- Electroflotation and electroflocculation



**Fig 5.** Image showing flocculation of microalgae. Progression of process is left to right.

# BACKGROUND INFORMATION - ELECTRIC SEPARATION

- Electro-flocculation
  - Separation of algae cell from medium
- Pulsed Electric Field Lysis (PEF Lysis)
  - Algae cell lysis; oil extraction and biomass flocculation
  - Pulsed electric fields cause cell poration
  - Reduce post-processing of biomass



# KEY TECHNICAL CONSIDERATIONS

- This is a fundamentally interdisciplinary project.
- There are five main technical considerations which will direct the evolution of this project, including:
  - Cultivation process
  - Scalability
  - Harvest 1 gram of biomass per liter of culture
  - Space efficiency optimization
  - Minimal loss system by recycling medium

# PROJECT OBJECTIVES

- Biomass production process must be fully automated.
  - Batch, semicontinuous, and continuous collection.
- Must have ability to separate produced biomass and clarified medium.
- Must minimize energy and resource consumption.
- System must be scalable.
- System will work with different species of algae.

# CONSTRAINTS

- The clarified medium must be recycled.
- The produced biomass must remain usable as biomass is intended for biodiesel.
- The entire system's flow rate will be dictated by the growth rate of the utilized microalgae. The growth rate of each algae is different and therefore the system must be able to adapt.



# CONCEPT DESIGN : REVISITED

GENERATION AND SELECTION

**Table 1.** House of quality.

		Importance	Engineering Characteristics					Customer Total	Percentage	
			Amount of biomass	Resistance to corrosion	Cost of Energy	Micro-Controller Timing	Biomass extraction efficiency			Design of Clarifier
Customer Requirements	Fully automated	5			1	9		3	65	22.90%
	Separate biomass	5	1			3	9	1	70	24.60%
	Works with different cycles	3	3			1			12	4.20%
	Continuous Flocculation + Sedimentation	5				9			45	15.80%
	Sustainable	3		9	9				54	19.00%
	Scalable	2	3					9	24	8.50%
	Works with different algae	2	1				3	3	14	4.90%
	<b>Total</b>			22	27	32	108	51	44	
<b>Percentage</b>			7.70%	9.50%	11.30%	38.00%	18.00%	15.50%		

# DESIGN BREAKDOWN

## FSU Led Cultivation Initiative

- Medium Component Design
  - Preparation, input parameters
- Cultivation Design
  - Growth
  - Distribution
- Sensor and Automation

## UFPR Led Harvesting Initiatives

- Design of Flocculation Process
  - Coagulation
  - Flocculation
- Separation and Extraction of Biomass
- Sensor and Automation



# CONCEPT DESIGNS

## FSU Led Cultivation Initiative

- Composition Sensors
  - Displacement
- Culture Constituent Mixing
  - Aeration
- Structural Design
  - Vertical rectangular container
- Fluid Transfer Mechanism
  - Solenoidal Valve

## UFPR Led Harvesting Initiatives

- Coagulative Mixing
  - Static Inline Mixer
- Flocculation
  - Inline Bulb Mixer
- Clarification and Sedimentation
  - Corrugated Angled Lamella Plates
- Extraction
  - Modified peristaltic pump
  - Sludge dewatering mechanism

# AUTOMATION

## FSU Led Cultivation Initiative

- Density Sensor and LED/Transistor pair (refilling)
- Solenoid Valves (transporting)
- Arduino (microcontroller)

## UFPR Led Harvesting Initiatives

- 2 Infrared LED's
  - Looking into potential alternatives
    - Image processing
- Phototransistors
  - Magnitude of light

Fig 6 Automation devices::



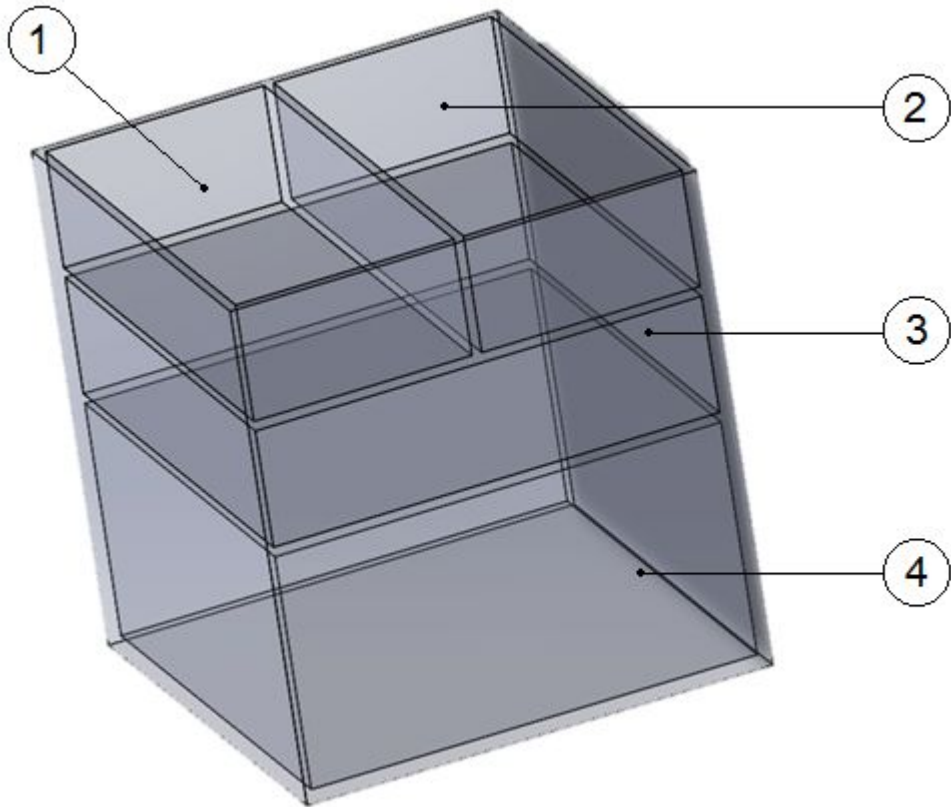

- 1) CHU Medium
- 2) Distilled water
- 3) Medium Component Homogenizer and recycled clarified medium
- 4) Cultivation Tank

# CULTIVATION PROGRESS - SETUP AND GROWTH

- Purchased Scenedesmus Obliquus Algae and Chu medium
  - Algae supplier: University of Texas
- Setup of cultivation infrastructure
  - Modified Shelf
  - Light fixtures
  - Air pump
  - Hosing
- Cultivation of algae has commenced



Fig 8. Picture of algae setup similar to FSU infrastructure.

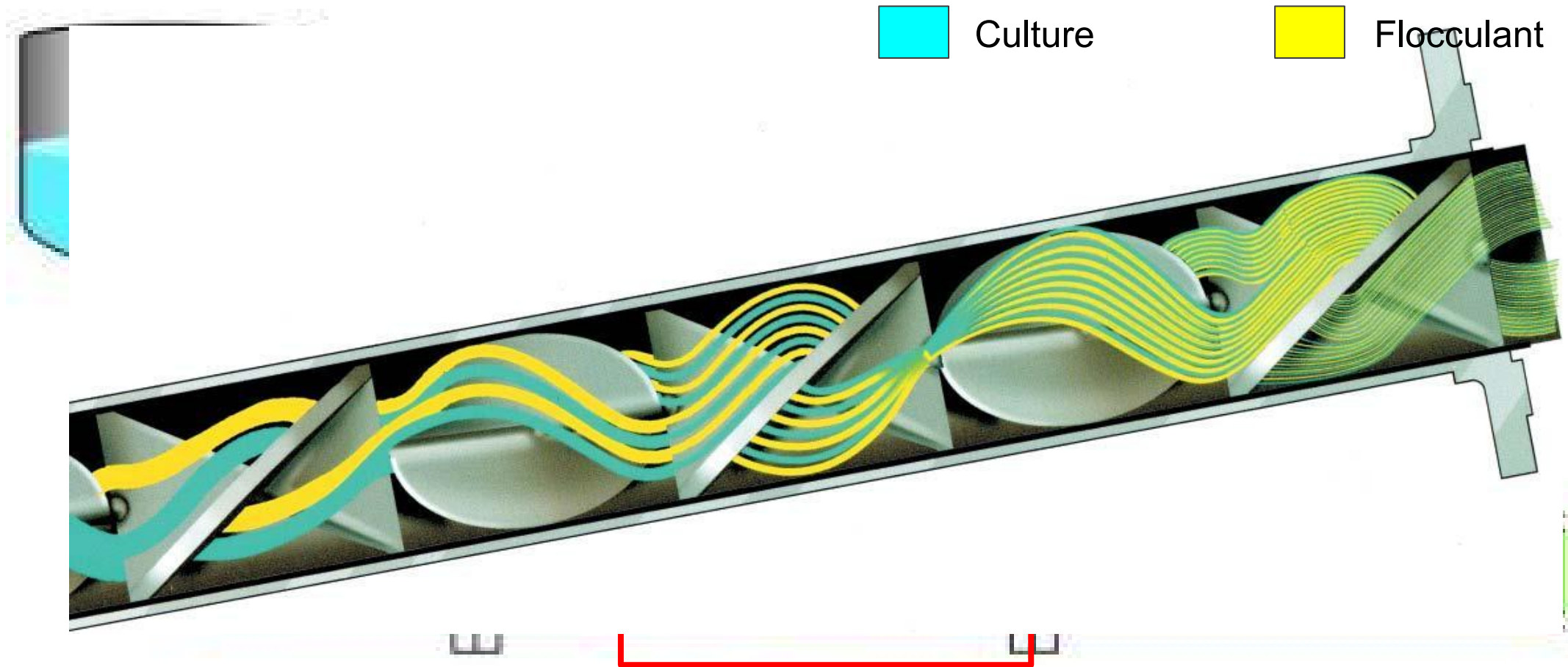

## STATIC INLINE MIXING

Fig 9. Visualization of static inline mixing process.



# FLOCCULATION - MIXING

Circular bulb mixers will be implemented to promote gentle mixing to allow more uniform formation of clots for more rapid sedimentation upon entranced into the clarifier tank.

Fig 10. Flow visualization for flow inside of a sphere.

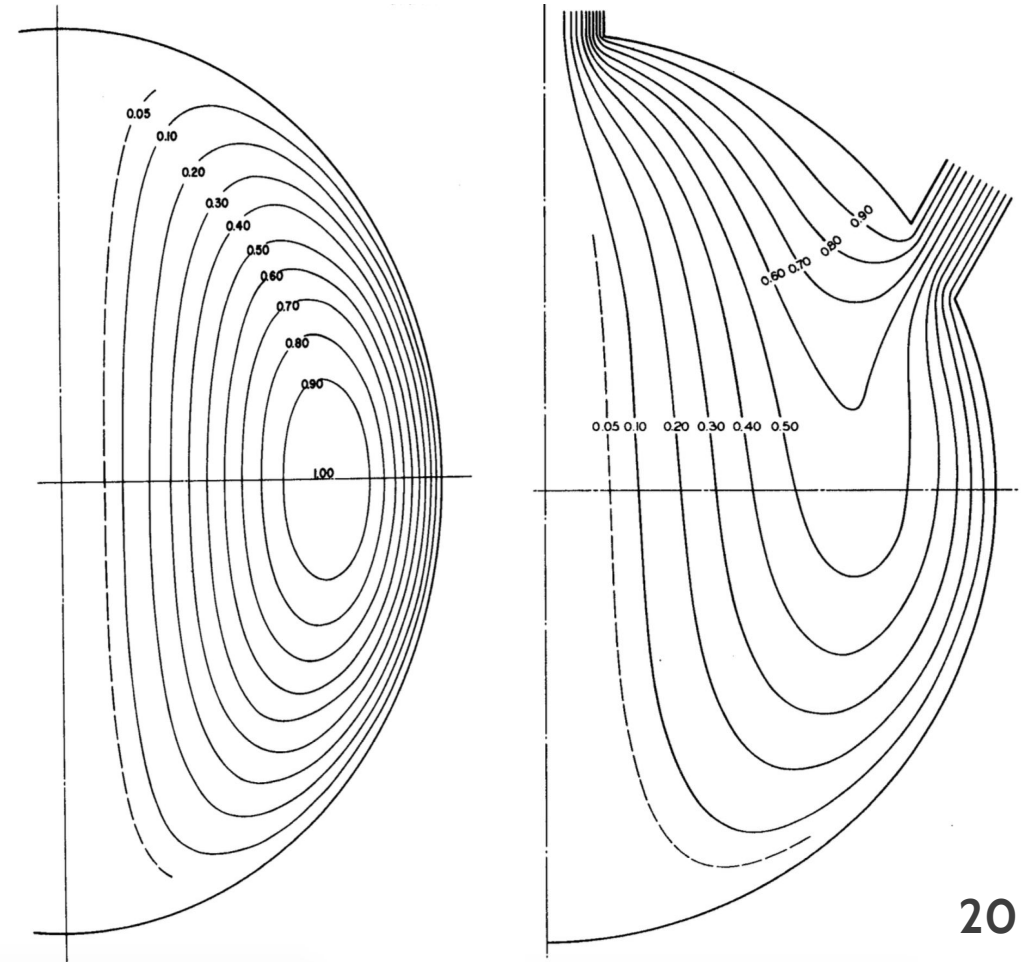



# FLOCCULANT TESTING

- Testing with three main objectives:
  - Approximate settling time
  - Approximate sedimentation velocity
  - Investigate correlation between flocculant concentration and effectiveness
- Flocculant was tested
  - Tanfloc

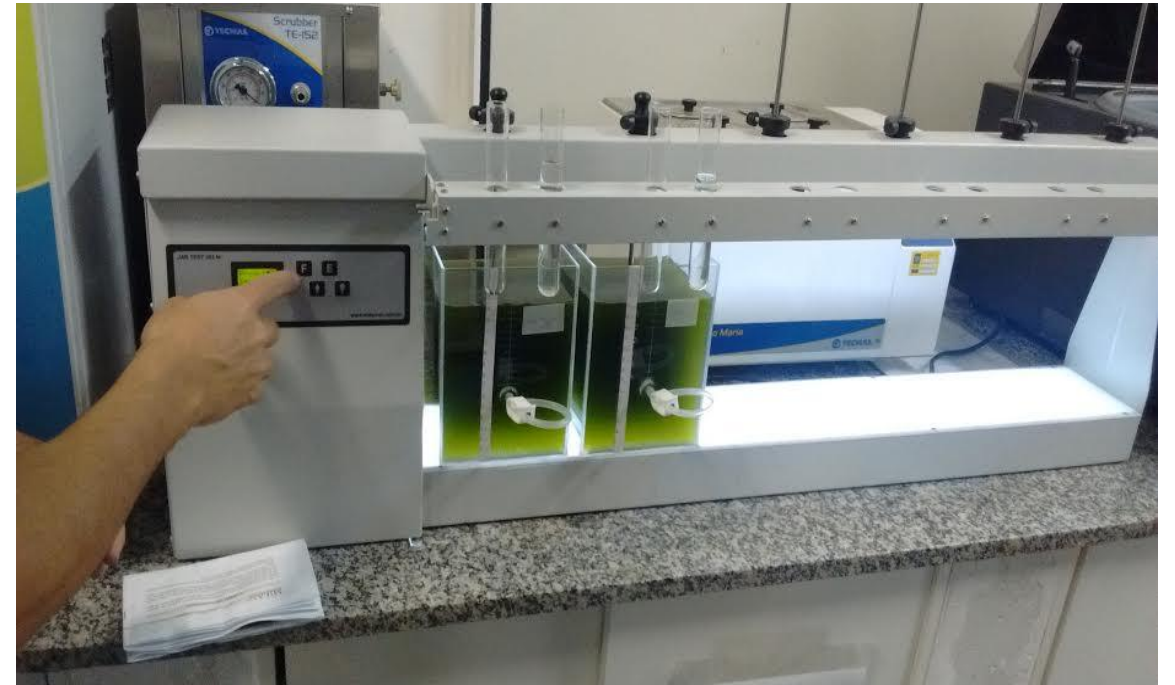

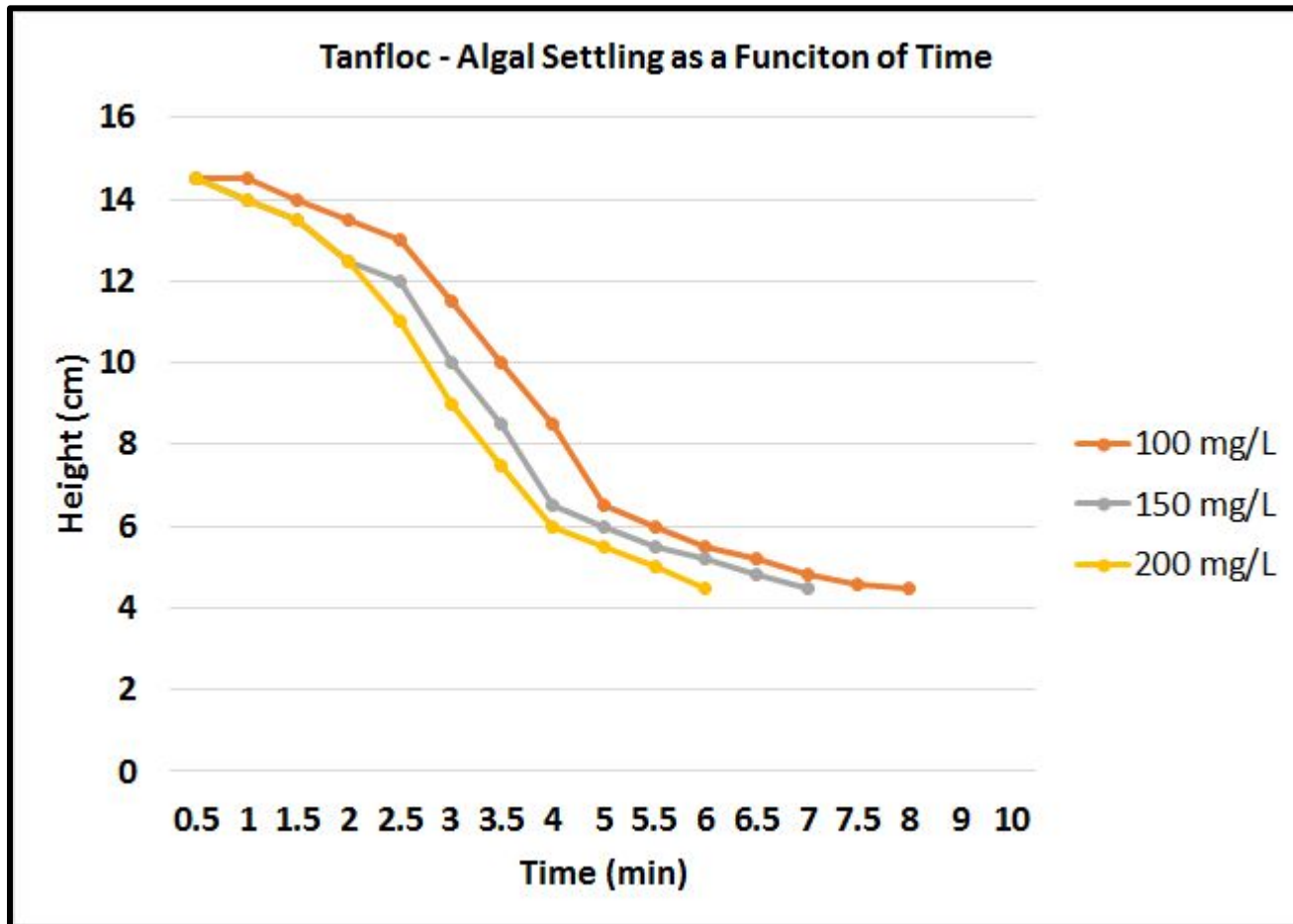

TANFLOC			
Concentrations (mg·L <sup>-1</sup> )	100	150	200
Clarity *	2.5	1	1
Sedimentation Velocity (cm·s <sup>-1</sup> )	0.0151	0.0195	0.0205

**\*NOTE(S):**

- Clarity is classified from 1 (low turbidity) to 5 (high turbidity).

TANFLOC TESTING RESULTS

Fig 11. Visualization of static inline mixing process.  
 Table 12. Table of Tanfloc testing results including test concentrations, final water clarity, and sedimentation velocity.

Cost comparison for different separation processes.

Separation processes	Reference	Year	Cost (\$kg <sup>-1</sup> biomass)		Items included in the processing cost
			Original <sup>c</sup>	2012	
Centrifugation – self cleaning plate	[3]	1995	1.71	2.58	Plant depreciation, maintenance and energy
	[7]	1988	0.86 <sup>a</sup>	1.68	Equipment depreciation, maintenance and energy
Flocculation – sedimentation	[7]	1988	0.37 <sup>a</sup>	0.72	Plant depreciation, maintenance, flocculant and energy
	[4]	1996	1.25	1.83	Plant depreciation, maintenance, flocculant and energy
Flocculation – flotation	[3]	1995	1.39	2.10	Plant depreciation, maintenance, flocculant and energy
	[7]	1988	0.91 <sup>a</sup>	1.78	Plant depreciation, maintenance, flocculant and energy
Electro-flocculation	[9]	1997	0.22	0.31	Energy only
Microbial flocculation	[21]	2010	0.29 <sup>b,d</sup>	0.31	Plant depreciation, maintenance, raw materials and energy
Electro-flocculation		2012		0.19	Plant depreciation, electrode dissolution and energy

<sup>a</sup> US \$1 = DM 1.85 in 1988.

<sup>b</sup> US \$1 = A \$1.1 in 2010.

<sup>c</sup> US consumer price index in 1988, 1995, 1996, 1997, 2009 and 2012 are 115.7, 150.3, 154.4, 159.1, 211.1 and 226.6 respectively.

<sup>d</sup> Typical biomass concentration is assumed to be 0.5 kg m<sup>-3</sup>.

## EVALUATION OF FLOCCULATION

Fig 13. Cost comparison of different flocculation processes.

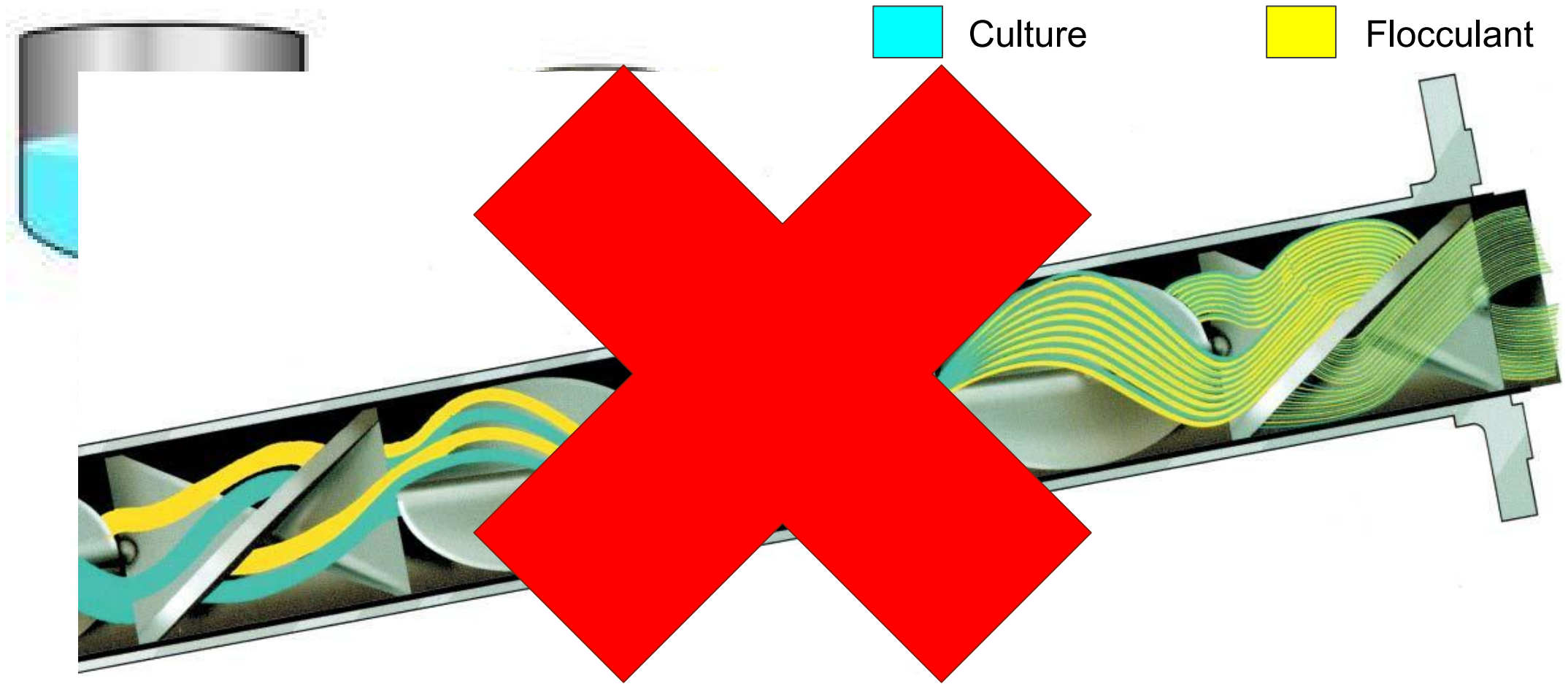

## STATIC INLINE MIXING

Fig 14. Visualization of static inline mixing process.

# PULSED ELECTRIC FIELD

- a. The cell membrane under the Home Potential ( $R$ ) (equivalent circuit represented in the membrane)
- b. External Electric Field ( $E$ ) increases the potential of the membrane, causing compression of the membrane.
- c. A further increase in the external electric field leads to the critical potential of the membrane and subsequent formation of pores.
- d. If the external electric field becomes too large, large pores will be formed.

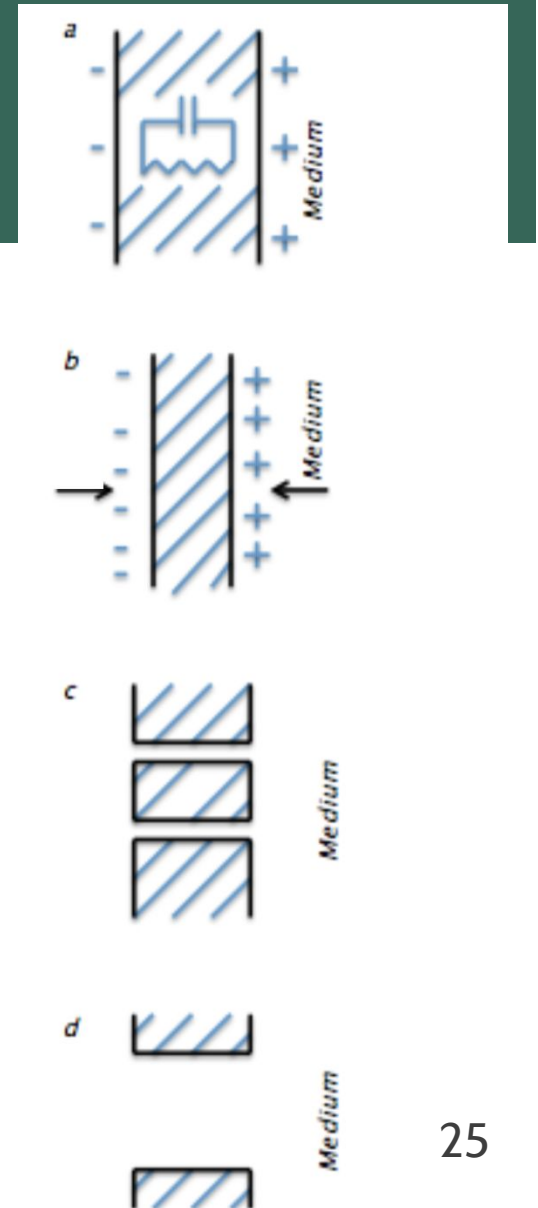

Fig 15. Pulsed Electric Field Process.



# PULSED ELECTRIC FIELD LYSING

- Requires low energy expenditure
- Capacitors are charged and discharged to create the pulsed electric fields
- Governed by microcontroller

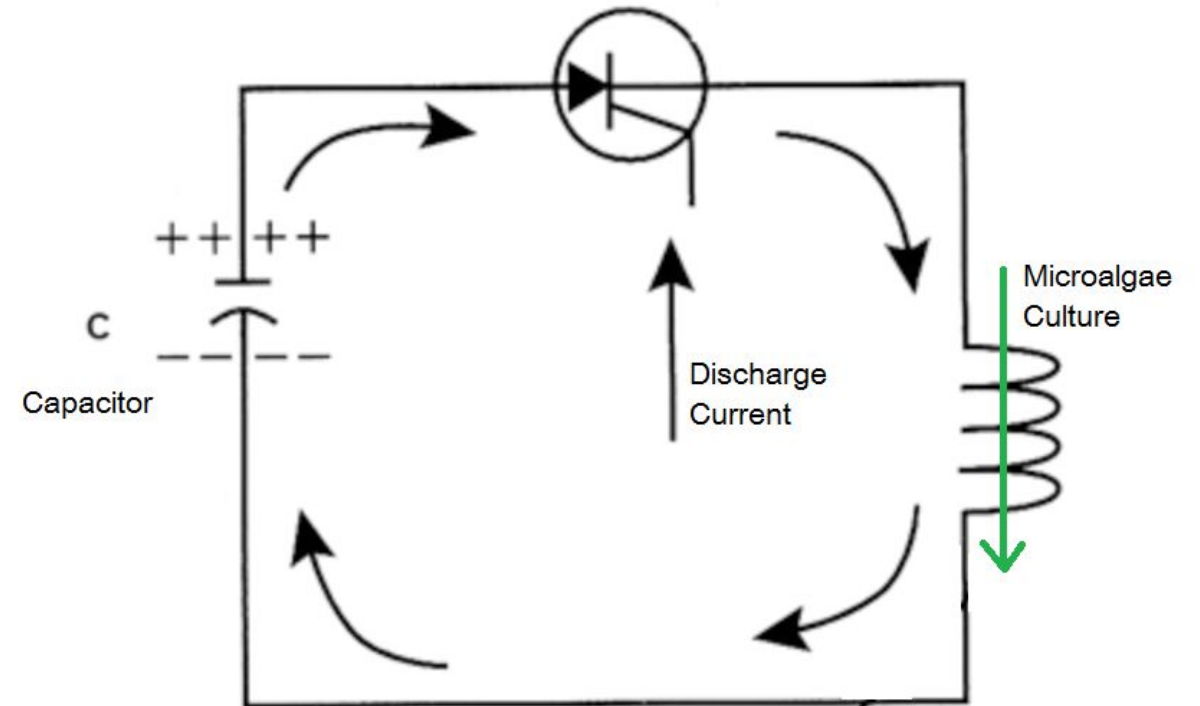

Fig 16. System schematic of pulsed electric field lysis.



# PULSED ELECTRIC FIELD LYSING

- Lysing the algae cells will cause the oil and organelles to leak out.
- Oil extraction and biomass sedimentation become one process.
- Removes the additional need for centrifugation and additional manual or chemical oil extraction process after flocculation.

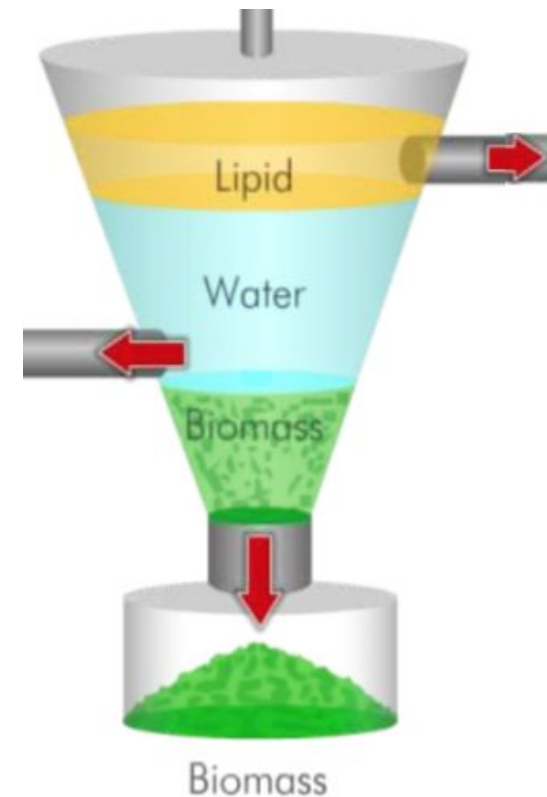

Fig 17. Visual representation of intended results of pulsed electric field lysis.

# MATHEMATICAL MODEL AND EXPERIMENTS FOR PEF LYSIS DESIGN

## Empirical Tests

- Several experiments will be conducted to validate the model.
  - Efficiency, feasibility etc.
- An equivalent jar test for settling velocity of the lysed cells will be conducted as well to ensure proper clarifier dimensionalizing.

# MATHEMATICAL MODEL

- Based on the assumptions listed, process efficiency can be defined as:

$$\eta = \frac{N_{lys}}{2 \cdot N_0}$$

Where,  $N_{lys}$  is the number of lysed cells  
 $N_0$  is the number of initial whole cells

- A transient model will be created to find the response time needed to reach steady state.
- A system of differential equations, based on the dimensionless mass of each lysed and whole cell system, is to be solved to obtain the maximum flow rate for complete lysis (~95%).

$$\frac{dm}{dt} = \dot{m}_{in} - \dot{m}_{out} + \mu$$

Where, the lysis rate  $\mu$  is a function of mass flow rate, time, and PEF energy. To be determined through literature or empirically.

- Note -  $\mu$  is expected to be a step function due to the pulsed nature of the applied field.

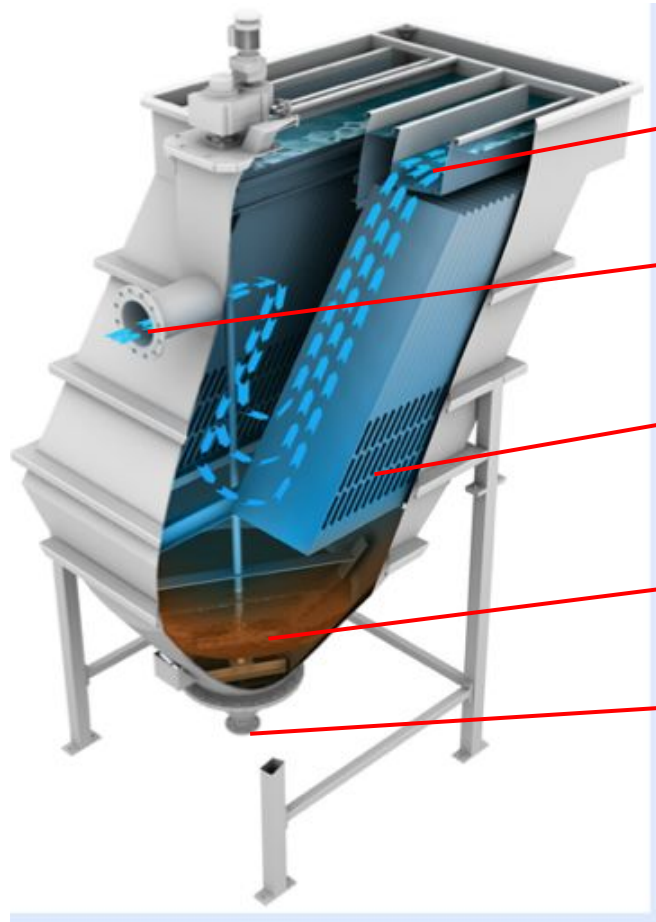

Dam - discharge outlet of the clarified medium

Entry - From flocculation stage

Lamellas - corrugated to increase surface area

Sludge Blanket

Extraction / dehydration - modified peristaltic pump

## CLARIFICATION AND SEDIMENTATION

Fig 18. Representation of a basic lamella separator.

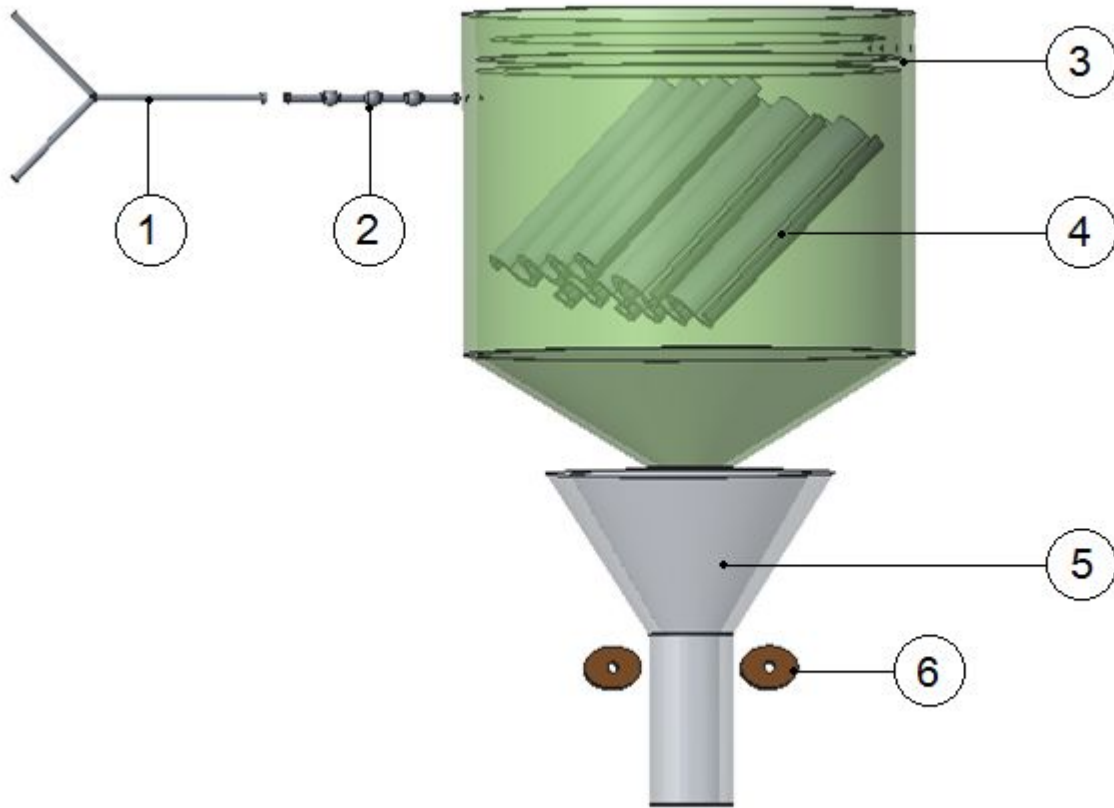

- 1) Static Inline Mixer
- 2) Inline Bulb Mixer
- 3) Clarifier Tank
- 4) Angled Lamella Assembly
- 5) Flexible Dewatering Extraction Channel
- 6) Modified peristaltic pump

# RISK AND CHALLENGE IDENTIFICATION

## FSU Culture Initiative

- Light and CO<sub>2</sub> distribution in larger scale systems
- Preventing medium evaporation
- Ensuring longevity of live algal cultures

## UFPR Harvesting Initiative

- Modeling and designing PEF lysing system components
- Design of a modified peristaltic pump to extract biomass
- Implementation of a flexible sludge dewatering mechanism

# LOGISTICAL CHALLENGES

## Current Challenges

- Sustaining algal growth at FSU
- Geographically dispersed team
- Optimization of pulsed electroflocculation

## Potential Challenges

- Sanitation and use of current photobioreactor skeleton
- Separate prototype development
- Development of numerical system models



# FUTURE PLANS

## FSU TEAM

- Finish designing and selecting the harvesting components
- Maintain project budget and inventory of supplies
- Continue to cultivate algae
- Begin small prototype build
  - Purchase and test sensors

## UFPR TEAM

- Finish dimensionalizing clarifier tank
- Electroflocculation tests and optimization
  - Mathematical model of electroflocculation efficiency as a function of time and applied voltage
- Lamella structures characterization
- Flocculator and clarifier prototype design

### Group 9 Gantt Chart: Semester 1

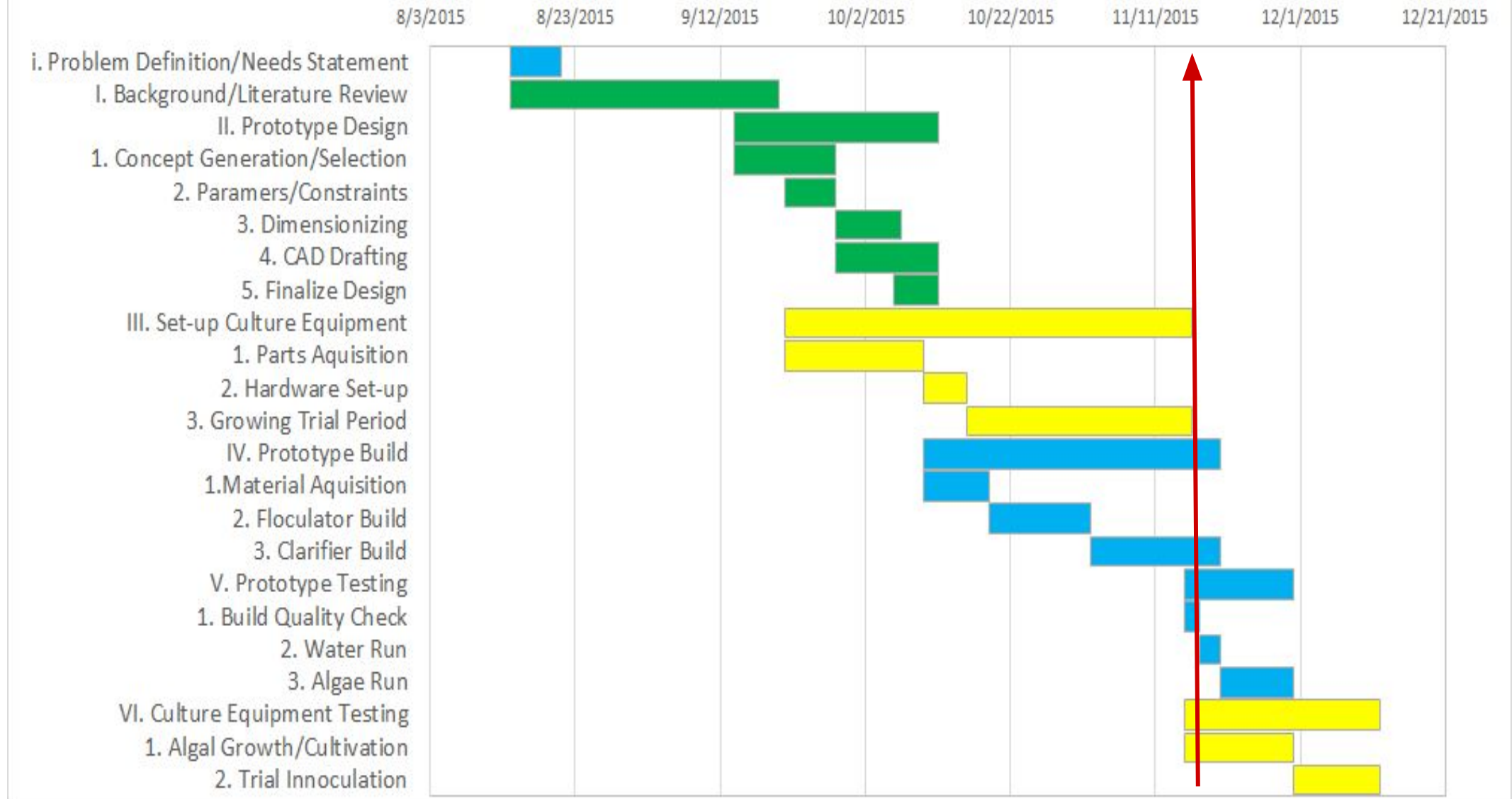

# SUMMARY

Component designs evaluated and selected based on needs and project objectives.

- Cultivation: Optimize efficiency and foster sustainable growth
  - Gravity and air pump to minimize moving parts and power
  - Solenoid valve and displacement sensor for automation of medium inputs
- Harvesting: Increase production and space efficiency, decrease production time
  - Pulsed electric field lysing will be used to flocculate biomass and extract oil
  - Lamella clarifier will be optimized based on shape and surface area
  - Peristaltic pump will be used in conjunction with flexible dewatering extraction channel







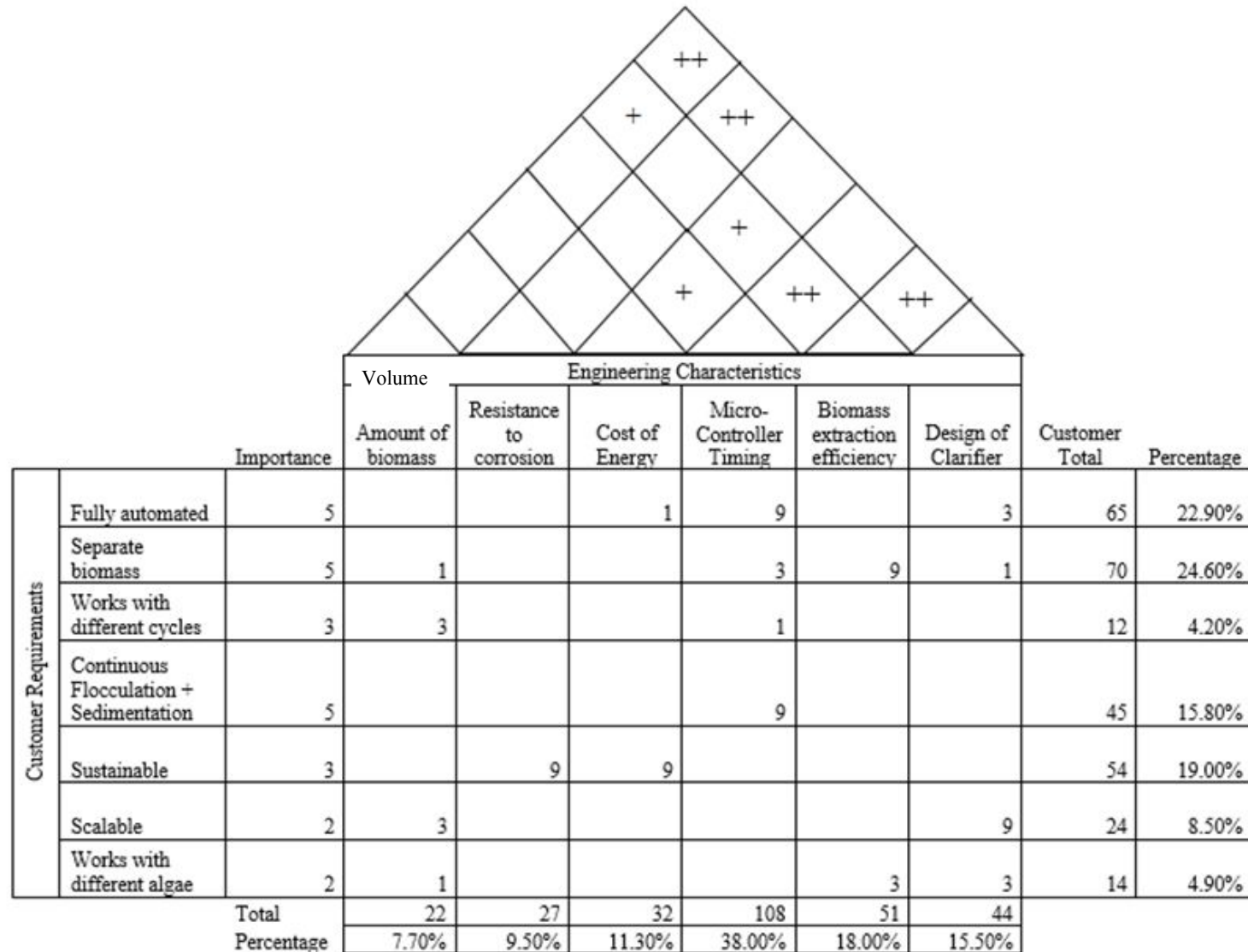



# Appendices

# Appendix A: House of Quality



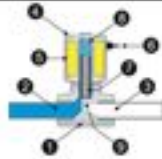

# Appendix B: Medium Preparation and Cultivation Concept Generation

Option	Solutions		
Function			
Composition Sensors	Volume	Force	Displacement
Mixing			
Structural Design			
Transferring Fluid			

**Fig B-1.** General morphological chart showing all generated component designs

























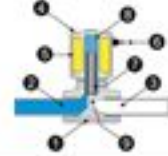

Option 1	Solutions		
Function			
Composition Sensors	Volume 	Force	Displacement
Mixing			 
Structural Design		 	
Transferring Fluid	 		

Fig B-2. Morphological chart showing all selected components for option 1

Option 3	Solutions		
Function			
Composition Sensors	Volume 	Force	Displacement
Mixing	 		
Structural Design			 
Transferring Fluid		 	

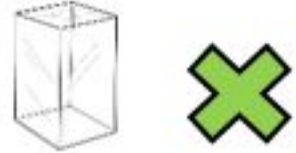
**Fig B-3.** Morphological chart showing selected components for option 3, a third possibility

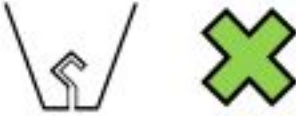
Function: Composition Sensors	Criteria					
Solutions (Weight)	Cost (2)	Size (1)	Power (2)	Effectiveness (3)	Implementation (2)	Total
1. Mass flow rate sensor	1	8	9	8	7	33
Volume	2	8	18	24	14	<b>66</b>
2. Force sensor (mat)	5	5	8	6	4	28
Force	10	5	16	18	8	<b>57</b>
3. Displacement sensor	10	9	9	6	8	42
Displacement	20	9	18	18	16	<b>81</b>

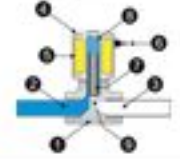
Fig B-4. Decision matrix for composition sensors



Function: Mixing (Medium)	Criteria					
Solutions (Weight)	Cost (2)	Size (1)	Power (2)	Maintenance (2)	Implementation (3)	Total
1. Static Inline Mixer	3	5	10	10	6	34
	6	5	20	20	18	<b>69</b>
Air pump	9	7	6	8	8	38
	18	7	12	16	24	<b>77</b>
Mechanical Mixer	2	4	4	3	4	17
	4	4	8	6	12	<b>34</b>

Fig B-5. Decision matrix for a mixing mechanism



Function: Structural Design Solutions (Weight)	Criteria					
	Cost (2)	Size (2)	Effectiveness (1)	Maintenance (2)	Implementation (3)	Total
1. Erlenmeyer Flasks 	2	6	5	8	5	26
2. Horizontal Tank 	4	12	5	16	15	52
3. Vertical Tank 	6	7	5	4	5	27
	12	14	5	8	15	54
	6	8	9	4	5	32
	12	16	9	8	15	60

Fig B-6. Decision matrix for structural design

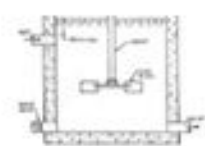









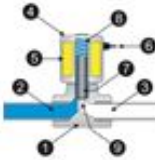

Function: Transferring Fluid	Criteria					
Solutions (Weight)	Cost (2)	Size (2)	Power (2)	Maintenance (1)	Implementation (3)	Total
1. Pump	3	3	2	4	7	19
	6	6	4	4	21	<b>41</b>
2. Auto Syphon	9	8	10	8	3	38
	18	16	20	8	9	<b>71</b>
3. Solenoid Valve	7	9	8	7	7	38
	14	18	16	7	21	<b>76</b>

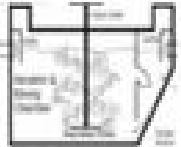
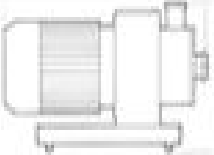
Fig B-7. Decision matrix for a fluid transfer mechanism

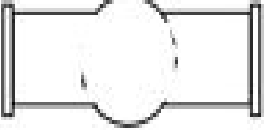
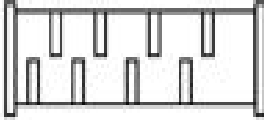



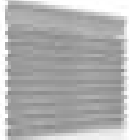

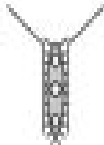
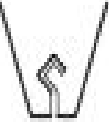
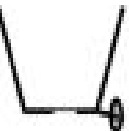

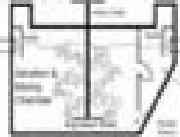
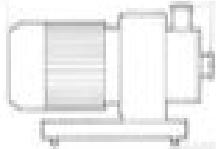

# Appendix C: Harvesting and Extraction Initiative Concept Generation

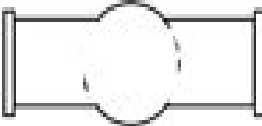
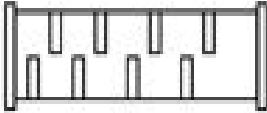



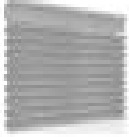

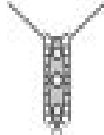
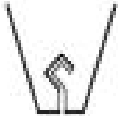
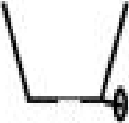

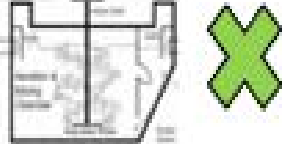
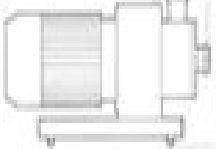

Option	Solutions				
Function					
Mix-Coagulation					.
Mix-Flocculation					.
Clarification					.
Extraction					

**Fig C-1.** General morphological chart showing all generated component designs

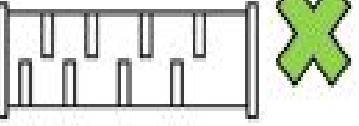



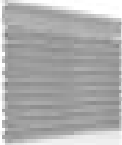

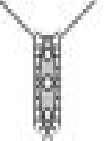
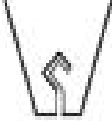
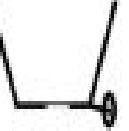



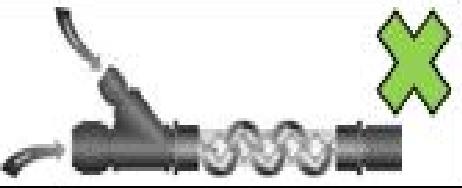
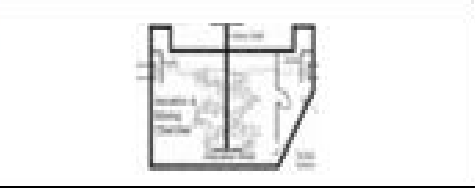
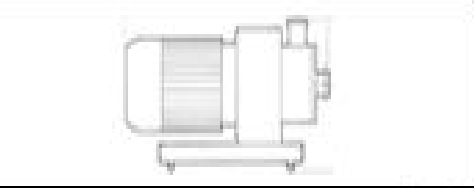
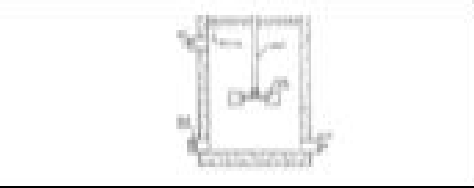

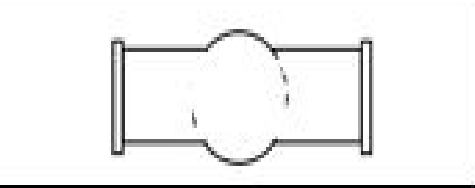
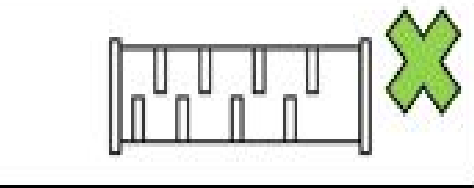
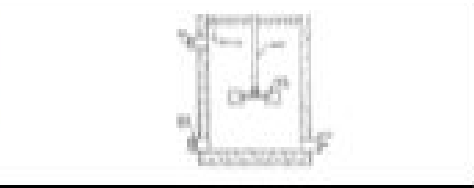
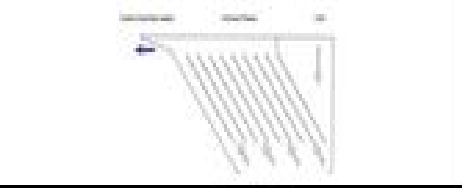
Option 0 - Control	Solutions				
Function					
Mix-Coagulation				 X	-
Mix - Flocculation				 X	-
Clarification	 X				-
Extraction	 X				

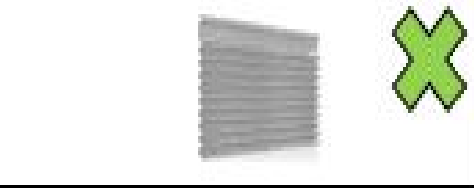
**Fig C-2.** Morphological chart showing all selected component designs for the control (standard) design

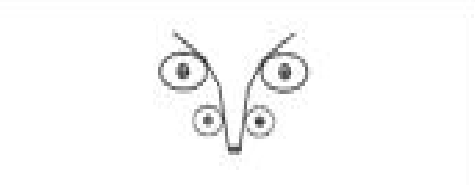
Option 2	Solutions				
Function					
Mix-Coagulation					.
Mix-Flocculation					.
Clarification					.
Extraction					

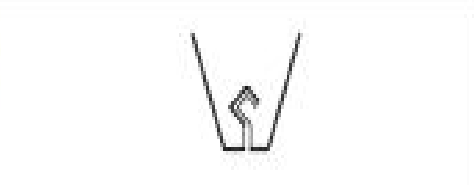
**Fig C-3.** Morphological chart showing selected component designs for option 2, all components were second highest rated

Option 3	Solutions				
Function					
Mix-Coagulation					-
Mix-Flocculation					-
Clarification					-
Extraction					

**Fig C-4.** Morphological chart showing selected component designs for option 3, created from a mixture of option 1 and 2 components

Function: Mixing (Coagulation)	Criteria					
Solutions (Weight)	Cost (2)	Size (1)	Power (2)	Maintenance (2)	Viability (3)	Total
1. Static Inline Mixer	8	9	10	7	6	40
	16	9	20	14	18	<b>77</b>
2. Aeration	9	5	6	5	7	32
	18	5	12	10	21	<b>66</b>
3. Inline Kinetic Mixer	2	7	4	3	5	21
	4	7	8	6	15	<b>40</b>
4. Kinetic Mix Tank	5	5	2	5	9	26
	10	5	4	10	27	<b>56</b>

Fig C-5. Decision matrix for component which fulfills function of coagulation- mixing

Function: Mixing (Flocculation)	Criteria					
Solutions (Weight)	Cost (2)	Size (1)	Power (2)	Maintenance (2)	Viability (3)	Total
1. Static Inline Mixer	8	9	10	7	6	40
	16	9	20	14	18	77
2. Mixing Bulb	9	8	10	8	8	43
	18	8	20	16	24	86
3. Baffles	10	9	10	6	8	43
	20	9	20	12	24	85
4. Kinetic Mix Tank	5	5	2	5	9	26
	10	5	4	10	27	56

Fig C-6. Decision matrix for component which fulfills function of flocculation- mixing

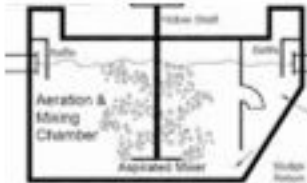
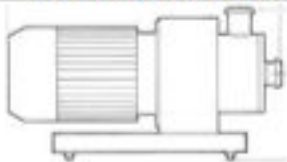
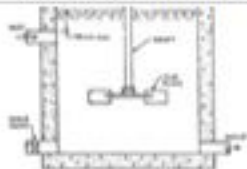

Function: Clarification	Criteria					
Solutions (Weight)	SA (3)	Cost (1)	Implementation (2)	Effectiveness (3)	Novel (1)	Total
1. Parallel Lamella Plates	6	10	10	5	1	32
	18	10	20	15	1	64
2. Conical Arrangement Lamella Tubs	5	7	4	7	7	30
	15	7	8	21	7	58
3. Parallel Angled Lamella Tubes	9	8	8	8	5	38
	27	8	16	24	5	80
4. Parallel Angled Corrugated Lamella Plates	10	7	8	10	7	42
	30	7	16	30	7	90

Fig C-7. Decision matrix for component which fulfills function of clarification

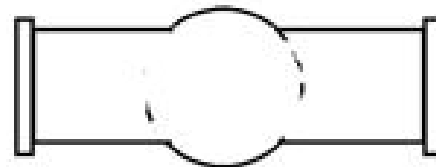
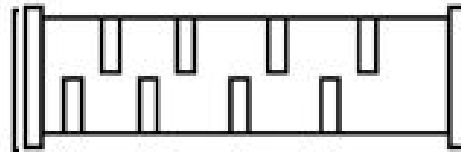
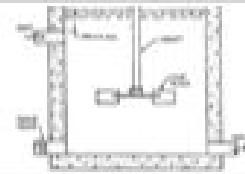



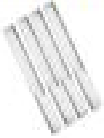
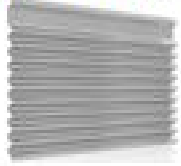

Function: Biomass Extraction	Criteria						
Solutions (Weight)	Cost (2)	Power (1)	Novel (2)	Viability (1)	Maintenance (2)	Effectiveness (2)	Total
1. Pump 	1	5	1	10	6	10	33
	2	5	2	10	12	20	51
2. Cam Swallow Mechanism	4	6	8	6	4	7	35
	8	6	16	6	8	14	58
3. Conveyor/Scrubber	5	6	5	7	4	8	35
	10	6	10	7	8	16	57
4. Autosiphon	7	8	5	7	5	2	34
	14	8	10	7	10	4	53
4. Free Fall Valve	8	8	1	8	8	2	35
	16	8	2	8	16	4	54

Fig C-8. Decision matrix for component which fulfills function of extraction

	Baseline	Alternative Solutions		
Criteria	Current Solution	Option 1	Option 2	Option 3
Cost	4	2	1	1
Sustainability	1	1	0	0
Adaptability	3	0	-1	0
Maintenance	2	1	-1	0
Effectiveness	5	1	0	1
$\Sigma$ Positives	-	16	4	9
$\Sigma$ Negatives	-	0	-5	0
Total	-	16	-1	9

Fig C-9. Pugh matrix for design configuration evaluation





# Appendix D: Harvesting and Extraction Initiative CAD Concept Drawings

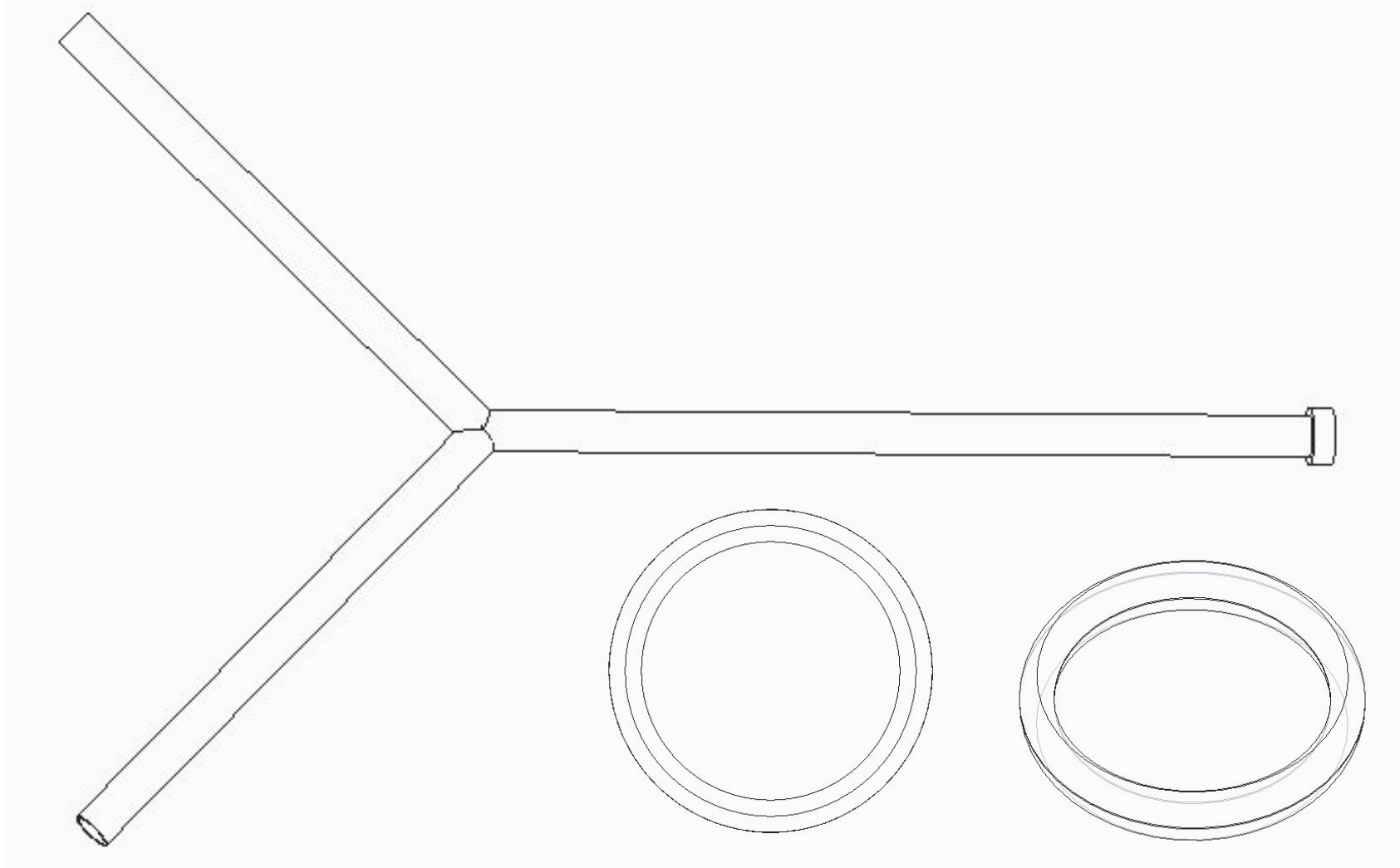

Fig D-1. CAD Drawing for 3 junction static inline mixer and seal used to prevent leaks in piping connections.

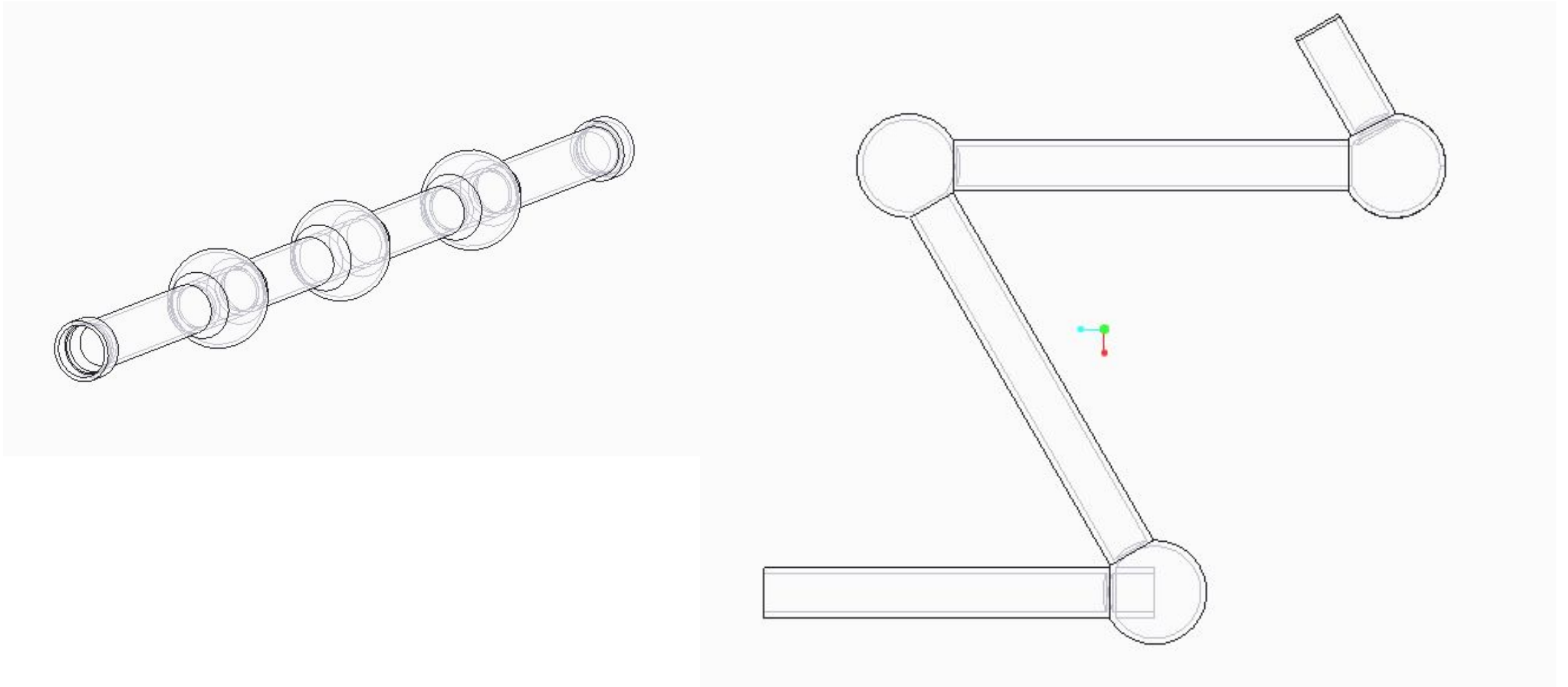

Fig D-2. CAD concept drawings of bulb mixing mechanism.

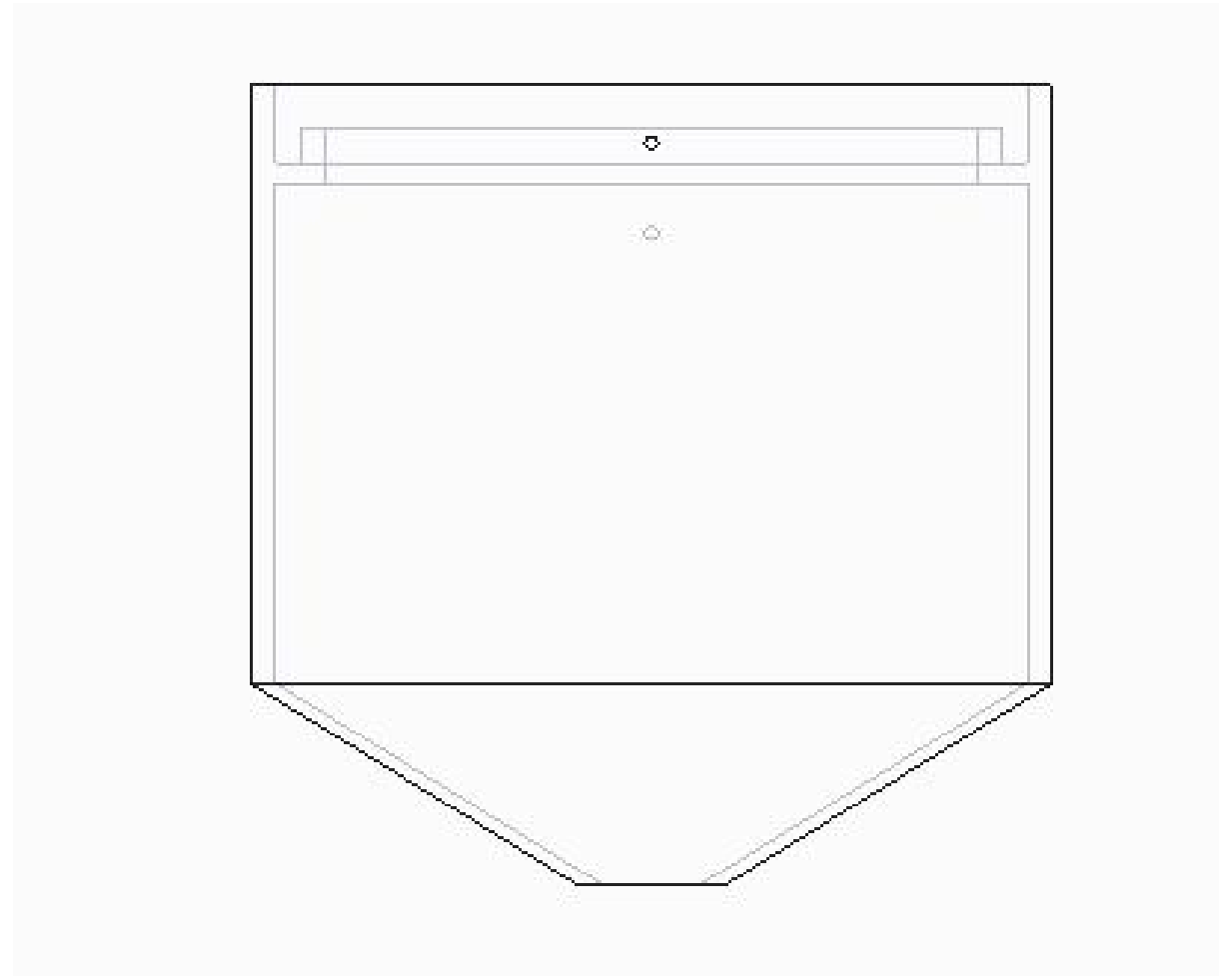
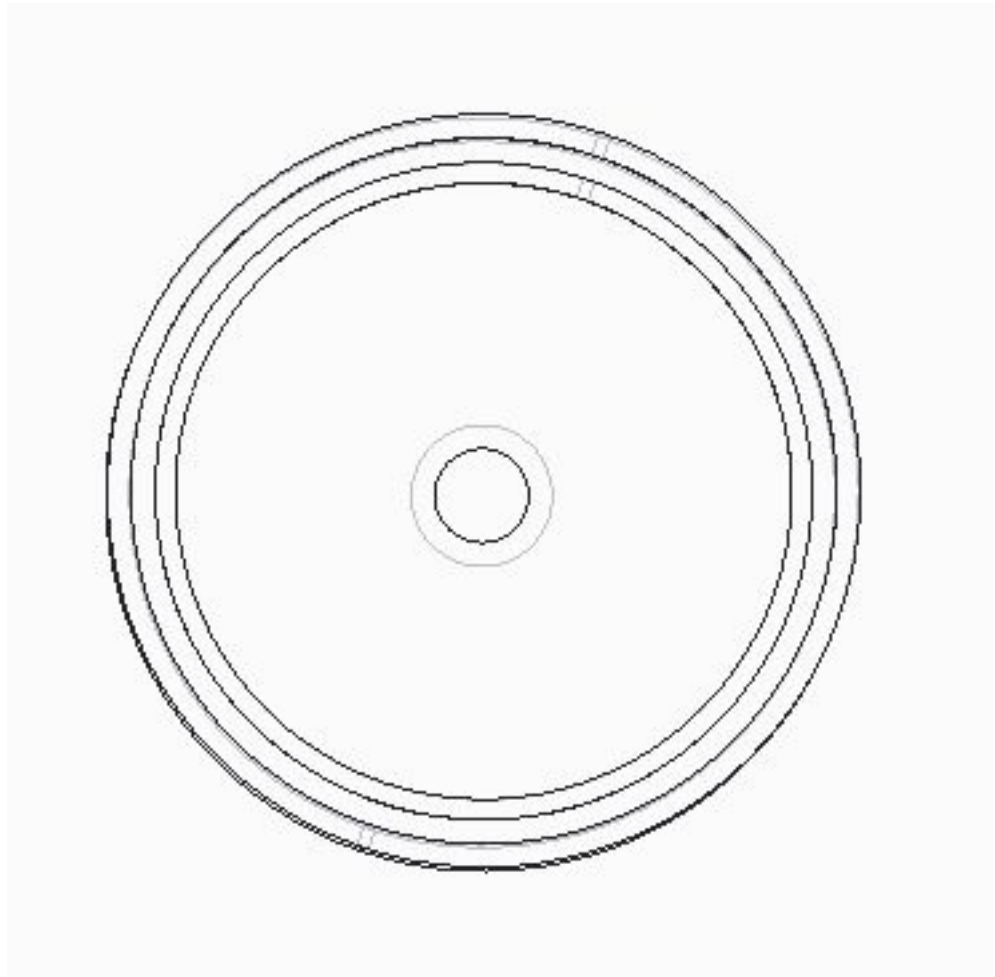

Fig D-3a,b. a. (Left) Top CAD drawing view of conceptual sedimentation tank, b. (Right) Profile view of sedimentation tank.

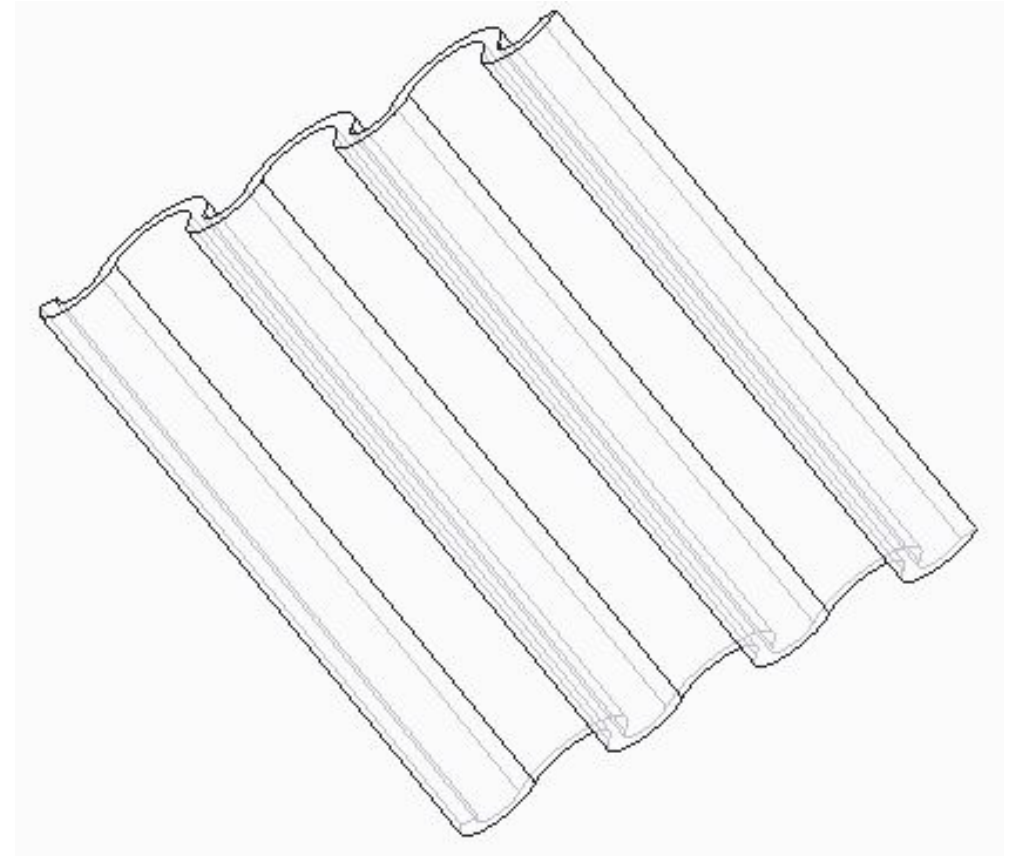
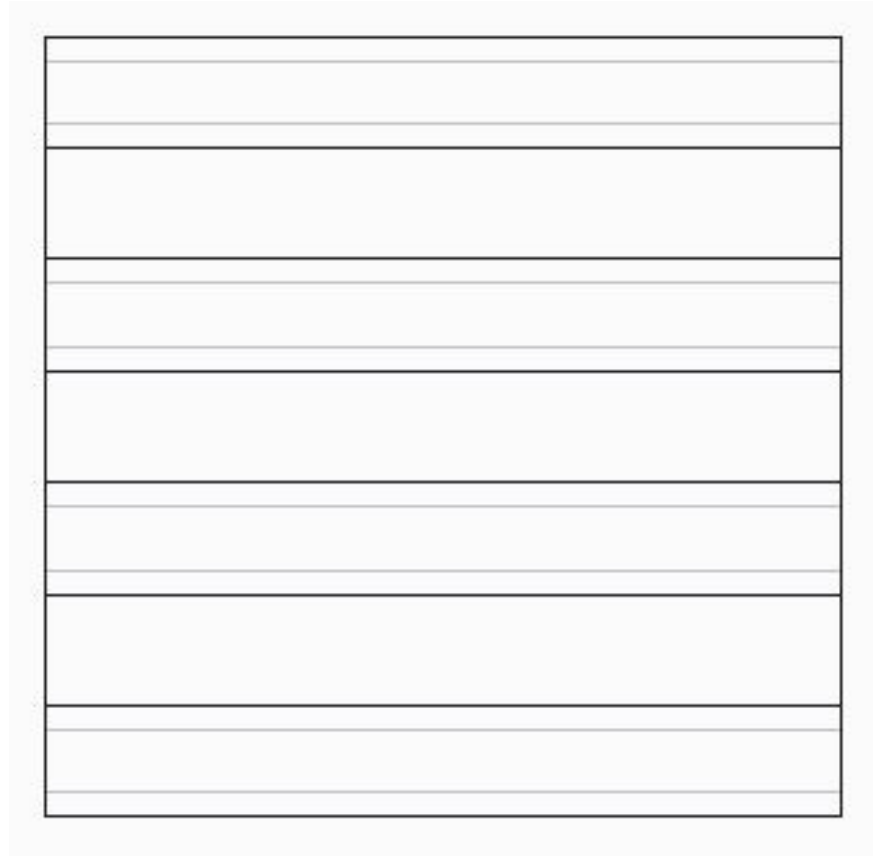

Fig D-4a,b,c. a) (Left) Profile view of conceptualized corrugated lamella, b) (Center) Front view of lamella, c) (Right) Default view of lamella.

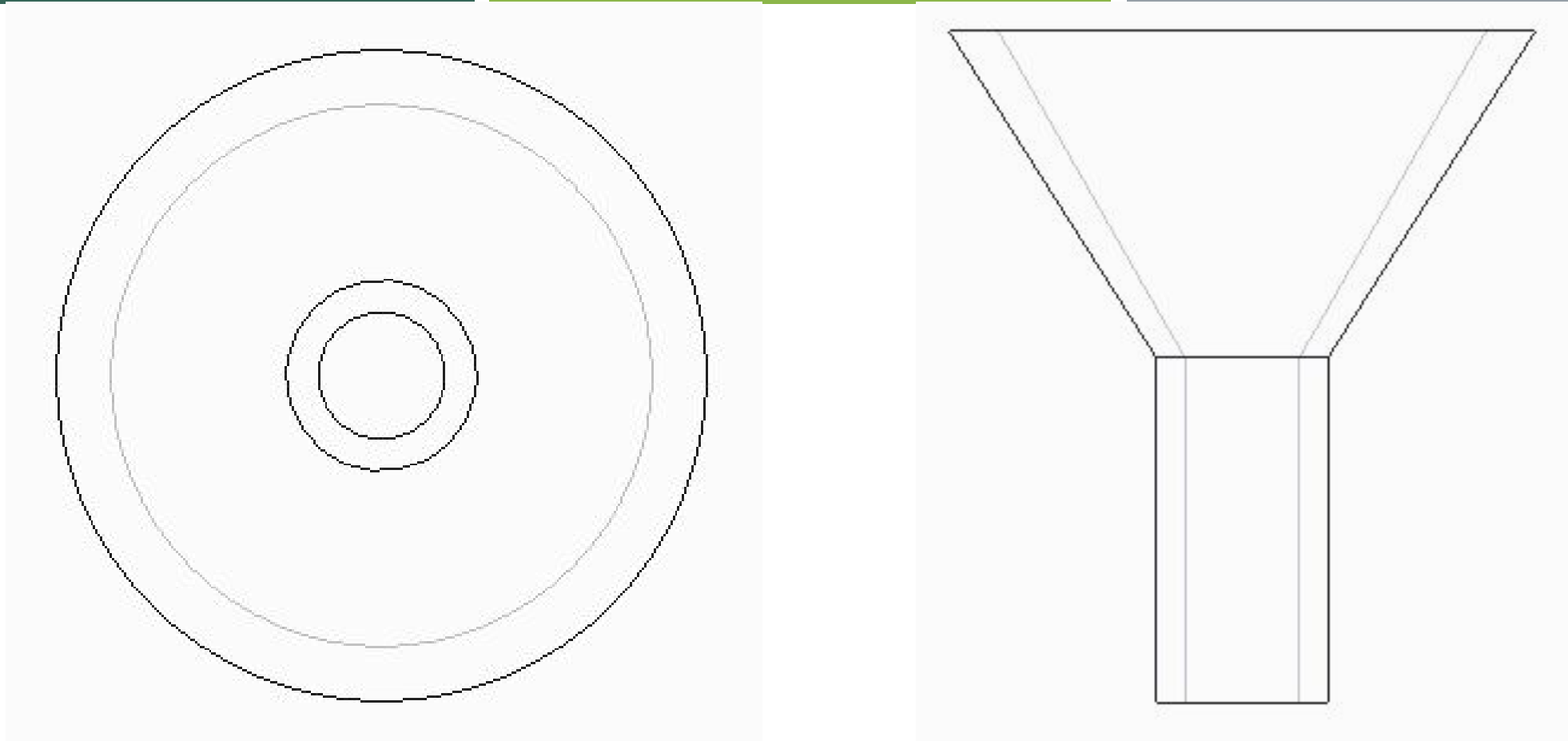

Fig D-5a,b. a. (Left) Top view of flexible extractor funnel, b. (Right) Profile view of funnel.

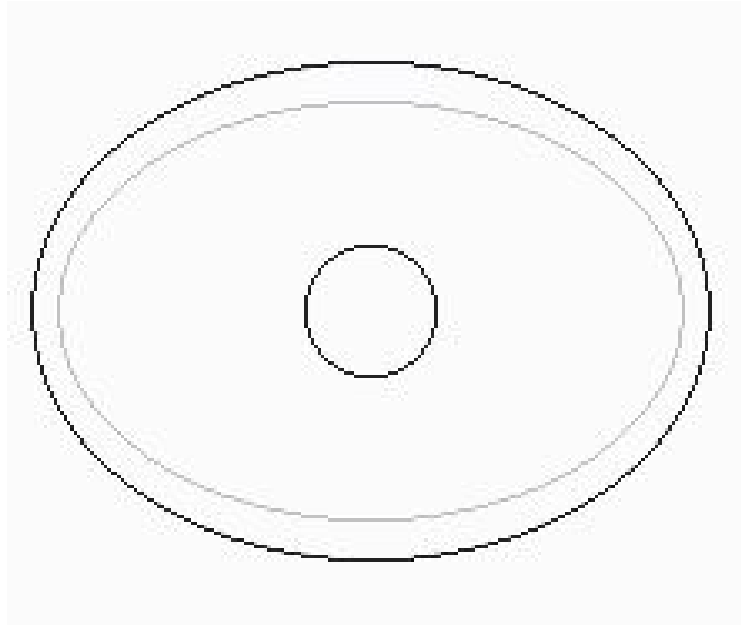

Fig 6 a,b. a) (Left) Profile View of concept cam to be used with extractor funnel, b) (Right) Longitudinal view of cam.